

THz Fabry-Perot Etalon

THz Fabry-Pérot Etalon (TFPE) is a Fabry-Pérot interferometer with fixed distance between reflecting surfaces made of plano-plano plate of high resistivity float zone silicon. The etalon is produced with better flatness and parallelism than a regular plano-plano window. Etalon thickness is measured to a high degree of precision.

General specification:

Material	HRFZ-Si
Type	THz Fabry-Pérot Etalon
Diameter range, mm	25.4-150
Aperture, %	>=90

TFPE is used as a thickness reference when performing calibration of TDS systems, adjustment of narrow-band THz sources and thickness measurements by spectral method in THz frequency range. Also TFPE can be used as a narrow-band filter (slight declination of the etalon allows adjustment of the transmission range).

Usage example

Calibrating TDS system process for precise measurement of sample thickness is an example of TFPE usage. Experimental setup is shown in fig. 1.

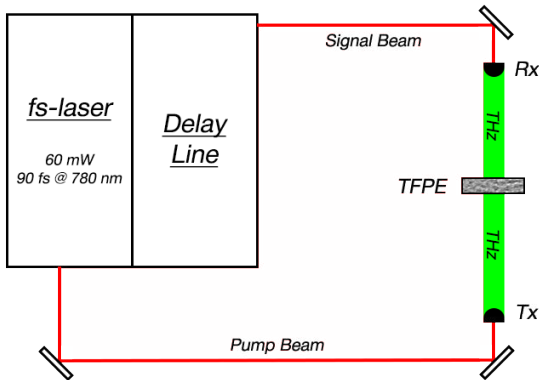

Fig. 1. Experimental setup

The experiment involves measurement of TFPE transmission spectrum and determining the distance between diffraction maxima (fig. 2). Given that distance and the refraction index of HRFZ-Si (3.416) the thickness of TFPE can be calculated.

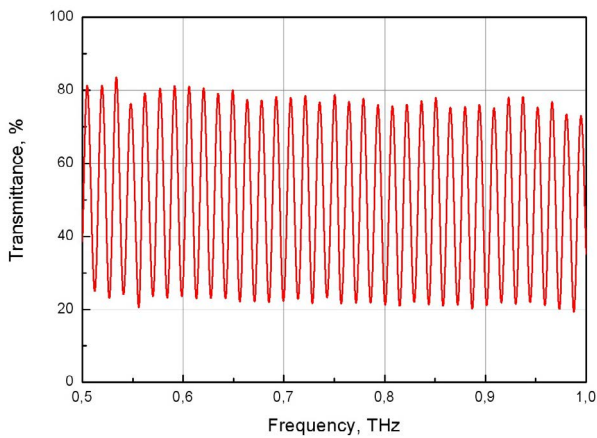

Fig. 2. TFPE transmission spectrum within 0.5 – 1 THz range at thickness 3.042 mm

The measured thickness value is to be the same as stated in the quality certificate. Any discrepancy shows that the TDS system requires adjustment.

Following TFPE are available from the stock:

Part number	Diameter	Rated thickness	Individual etalon parameters			
			Actual thickness*	Free spectral range (FSR)**	Bandwidth (full width at half maximum, FWHM) Δf	Finesse (F)**
	mm	mm	mm	GHz	GHz	-
TEFP-HRFZ-Si-D25.4-T3	25.4	3.0	3.042	14.4	5.5	2.6

*measured for each specific etalon with accuracy of 0.001 mm.

**Free spectral range (FSR) is a frequency offset between longitudinal modes of the TFPE. The free spectral range can be calculated as $FSR=c/(2*l*n)$, where c is the speed of light, l is the thickness of the TFPE, n is the refraction index of HRFZ-Si.

***Finesse (F) is the ratio of free spectral range to bandwidth (full width at half maximum, FWHM). The finesse can be calculated as $F=(2*\pi)/(-\ln(R^2))$. Where R is the reflection coefficient of the TFPE.

Please check our Optics stock (THz windows section).

Customer-specified TFPEs can be manufactured on request. Please fill in our Request Form to get a quote.